

Features

- Self contained flicker lamp.
- Frosted Glass Candelabra
- Anodized Aluminum Base
- Weather resistant (IP54)
- 110 Lumens 2200K 80CRI
other color temperatures available
- Flicker Flame functions with
programmable Levels, Randomness, and
Fade Rate.
- Vertical LED Configuration to enhance
flame movement.
- No external controller required
- Optional Hue Shifting
- Optional DMX-512 Control
- Wireless IR Programming
- 1/8" NPS All-Thread Mounting



Description:

The TCL series of lamp heads closely resemble a traditional Candelabra bulb. The unique vertical LED Configuration adds additional spacing between the two flicker circuits to enhance the sense of movement. This lamp should be installed behind a diffused shade.

Programming is done with a PC application, and an IR Programmer. This allows for easy field programming of the flicker effect after installation.

Flicker Flame

Realistic Flicker flame, Fire, and Candle effects can be created for each lamp. The effects are individually programmable with a variety of modes to simulate anything from glowing coals, to a raging inferno. No lookup tables or pre-recorded effects are used; each channel is truly random and unique.

Hue Shifting / Adjustable Color Temperature

The Hue Shifting function varies the Color Temperature based on intensity for a more realistic flame, or the CCT may be adjusted anywhere between 2200 (Warm white) and 1800K (Amber)

DMX-512 Control

The flicker effect can be modified by a remote DMX-512 controller. Any of the flicker effect settings may be mapped to a DMX-512 dimmer channel.

Programming:

The included PC application and IR Remote allows for easy programming from a PC or Laptop.

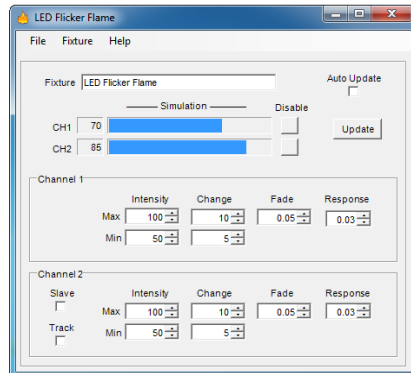

Dimensions / Mounting:

The lamp is supplied with a standard 1/8" NPS socket. Other mounting configurations are available.

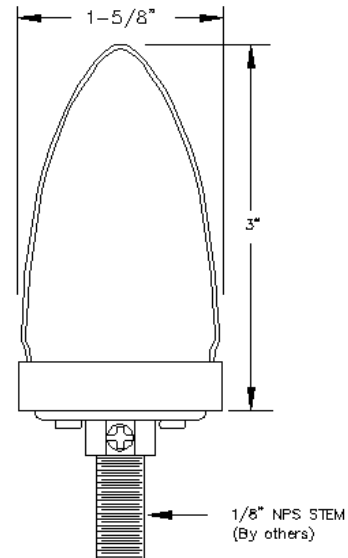

Specifications:

Power Input: 12V DC 250ma
 Environment: Dry or Damp Locations

Ordering Information:

TCL-150 2200K Color Temperature
 TCL-150-HS Hue Shifting (2200K – 1800K)

Products are custom engineered to meet your requirements.
 Contact us to discuss your application.

CHTC Enterprises, LLC
 20130 NW Nestucca Dr.
 Portland, OR 97229 USA

www.CHTC Enterprises.com
 503-350-0704
 sales@chtcenterprises.com

© 2019 CHTC Enterprises, LLC All Rights Reserved.
 Specifications subject to change without notice.
 Specification applicable to standard products only.
 Information furnished is believed to be accurate and reliable.
 However, no responsibility is assumed for its use.

